

P300 Pressure Regulator

- Minimize Sudden Downstream Load Change
- Wide Pressure Ranges
- P302 has internal relief valve for overpressure protection

The P300 series pressure regulator is a manual, direct acting, self-operating, spring loaded, adjustable regulator. The P300 series is used in applications where pressure reduction is required. The regulator will reduce the risk of "shock" from abrupt changes of downstream conditions. This can help prevent safety equipment from shutting an operation down.



Applications

- Compressors
- Gas Engines
- Service Regulators

Materials of Construction

Adjusting Screw	Aluminum
Body	Ductile Cast Iron or WCB Steel
Bonnet	Aluminum
Closing Cap	Zinc
Diaphragm	Nitrile
Lower Casing	Aluminum
Molded Seat Assembly	Nitrile
Orifice	Aluminum
Flange	Ductile Iron / WCB Steel

P300 Series Maximum Inlet Pressure

Orifice Inches	Range	P301/P302		P310H/P302H	
		Maximum Inlet Pressure		Maximum Inlet Pressure	
		PSIG	BAR	PSIG	BAR
3/16"	Any	125	8.618	125	8.618
1/4"	Any	60	4.136	125	8.618
3/8"	Any	30	2.068	80	5.515
1/2"	Any	25	1.723	60	4.136
3/4"	Any	15	1.034	40	2.757

Specifications

Maximum Inlet	See Table 1	
Maximum Emergency Outlet	15 PSIG	
Pressure Ranges	See Table 2	
Port Sizes	1.25 NPT	
	1.5 NPT	
	1.5 NPT x 2 NPT	
	2 NPT	
Orifice Sizes	3/16"	
	1/4"	
	3/8"	
	1/2"	
End Connections	3/4"	
	NPT	
	150 RF Flange	Steel Units Only
	125 FF Flange	Iron Units Only
Temperature Range	-20 °F to 180 °F	
	-29 °C to 82 °C	
Approx. Weight	26 lbs. (11.8 kg)	

P300 Series Range Springs

Table 2				
Model	Spring Ranges		Spring Color	Part Number
	WC.	mBar		
P301 & P302	3 - 6 WC	9 - 15	Red	655-788-000
	5 - 8.5 WC	12 - 21	Silver	655-788-001
	6 - 14 WC	15 - 35	Blue	655-788-002
	12 - 28 WC	30 - 70	Green	655-788-003
	PSIG	Bar		
P301H & P302H	1 - 2 PSIG	.07 - .14	Black	655-788-004
	1.5 - 3 PSIG	.10 - .21	Olive	655-788-005
	2.5 - 5.5 PSIG	.17 - .38	Yellow	655-788-006
P301H Only	4.5 - 8 PSIG	.31 - .55	Brown	655-788-007

P300 Part Matrix

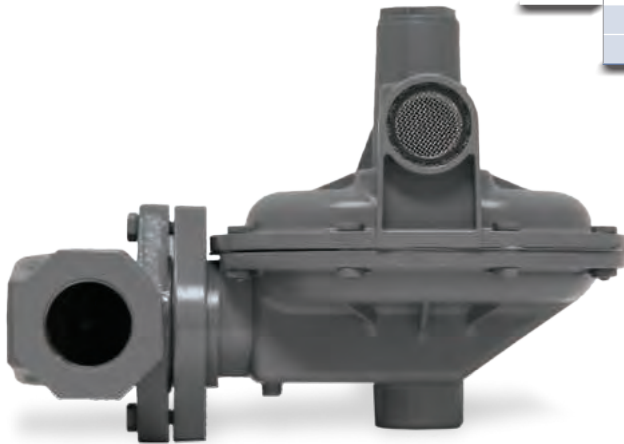

P30	↑	↑↑	↑↑↑	↑↑↑↑	↑	↑	↑	↑	↑	Version
1										Non-Relieving
2										Relieving
										Configuration
0										Normal
H										High
										Port Size
12										1.25 NPT
14										1.5 NPT
15										1.5 x 2 NPT
16										2 NPT
										Spring Range
										WC mBAR
006										3 - 6" WC 9 - 15
085										5 - 8.5" WC 12 - 21
014										6 - 14" WC 15 - 35
028										12 - 28" WC 30 - 70
										H Configuration
										PSIG BAR
002										1 - 2 PSIG .07 - .14
003										1.5 - 3 PSIG .10 - .21
005										2 - 5.5 PSIG .17 - .38
008										4.5 - 8 PSIG .31 - .55 301H Only
										Special Construction
0										None
A										150 RF (2" Steel Only)
E										125 FF (2" Iron Only)
										Orifice
3										3/16"
4										1/4"
6										3/8"
8										1/2"
B										3/4"
										Port Orientation
1										Up
2										Down
3										Right (Standard)
4										Left
										Bonnet Orientation
C										12 O'clock
D										3 O'clock
E										6 O'clock
F										9 O'clock (Standard)
										Body Material
0										Iron
2										Steel (2" Only)

P300 Regulator Rebuild Kits

	Kit Includes	Part Number
P300 Regulator	Diaphragm, Disk Holder, Cap Gasket, O-Ring	971-300-000

P300 Body Orientation*

* Port orientation is based on the body's "Out" port location in relation to the top view of the regulator.

P300 Vent Positions

P300 Dimensions

Body Size	A			A2			B	C	D	
	NPT	125 FF Flange	150 RF Flange	NPT	125 FF Flange	150 RF Flange	NPT	NPT	NPT	125 FF Flange
1.25	4.50			2.31			6.07	9.92	1.51	
1.5	4.50			2.31			6.07	9.92	1.51	
1.5 x 2	6.13			2.87			6.66	10.05	2.15	
2	6.13	10	10	2.87	5.00	5.00	6.66	10.05	2.15	

P300 Head Only

P30	0	Version
1		Non-Relieving
2		Relieving
		Configuration
0		Normal
H		High
		Spring Range
		WC mBAR
006		3 - 6" WC 9 - 15
085		5 - 8.5" WC 12 - 21
014		6 - 14" WC 15 - 35
028		12 - 28" WC 30 - 70
		H Version
		PSIG BAR
002		1 - 2 PSIG .07 - .14
003		1.5 - 3 PSIG .10 - .21
005		2.5 - 5.5 PSIG .17 - .38
008		4.5 - 8 PSIG .31 - .55 301H Only
		Special Construction
0		None
2		2" with Adapter for 2" BelGAS Body
		Bonnet Orientation
C		12 O'clock
D		3 O'clock (Standard)
E		6 O'clock
F		9 O'clock

P300 Standard

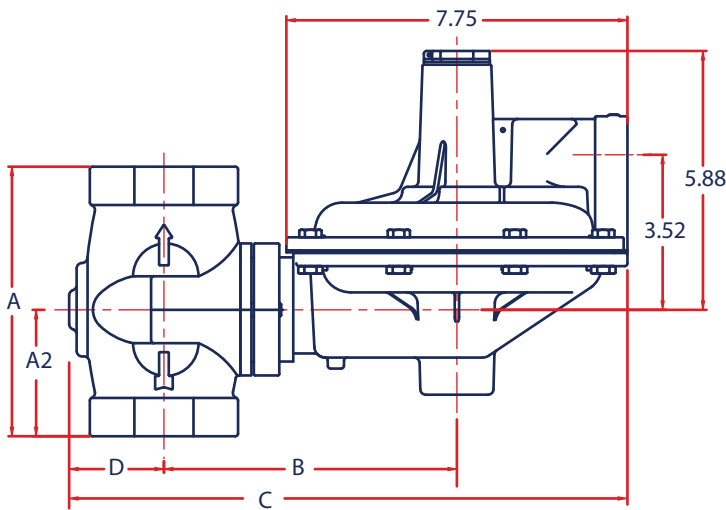

P300 Flanged

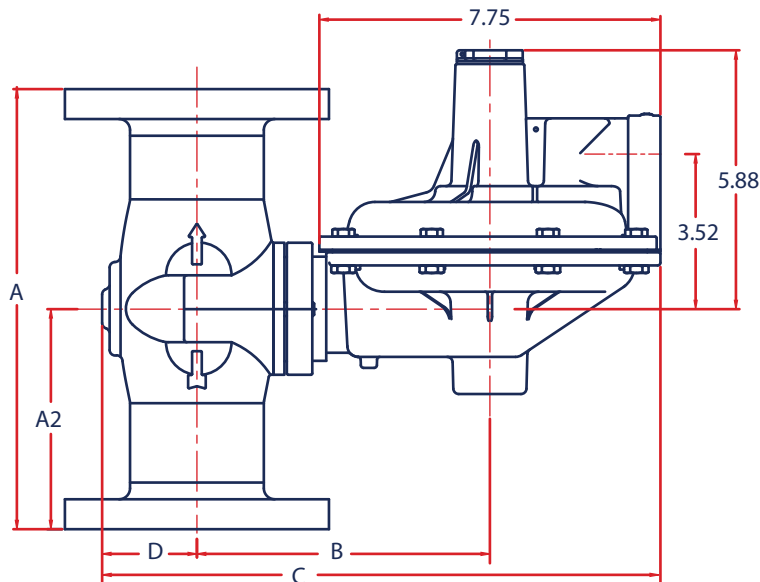

P302 Normal (0) Relief Capacities

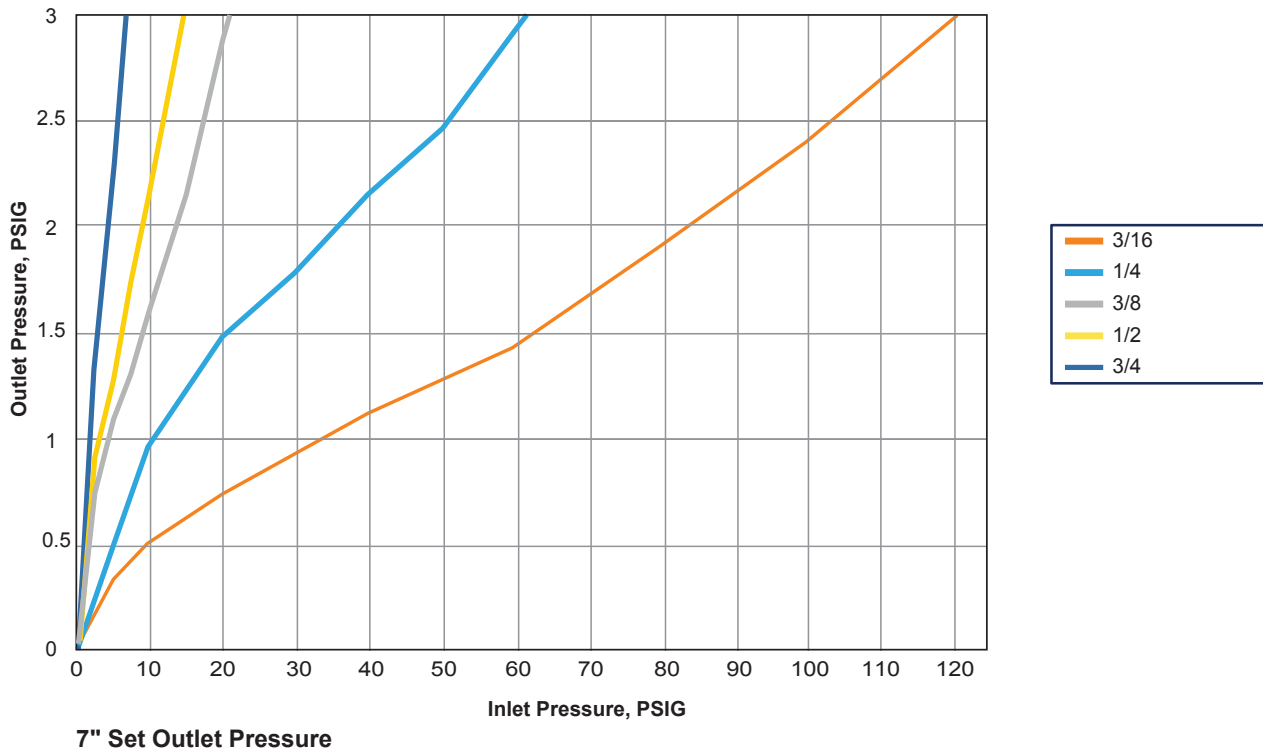

P302 H Relief Capacities

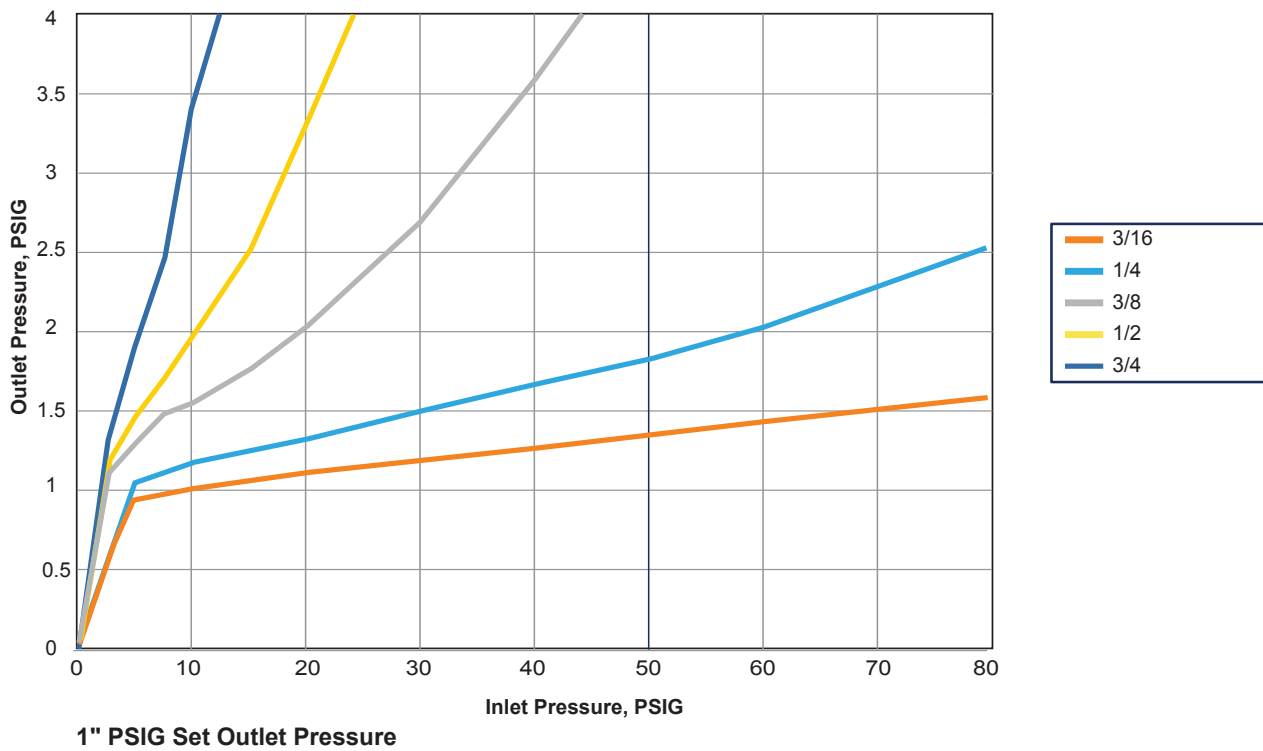

P301 & 302 Flow Capacities in SCFH (Nm³/h) of 0.6 Specific Gravity Natural Gas

Outlet Pressure, Spring Part Number, and Accuracy	Inlet Pressure		NPT 1-1/4 (DN32) Body Size				
			Orifice Size, Inches (mm)				
	PSIG	BAR	3/16 (4.8)	1/4 (6.4)	3/8 (9.5)	1/2 (13)	3/4 (19)
5 inches WC (12 mBAR) 655-788-000 1 inch WC (2.5 mBAR) droop	2	0.14			700 (18.8)	1000 (26.8)	1600 (42.9)
	5	0.34		700 (18.8)	1400 (37.5)	1900 (50.9)	2600 (70)
	10	0.69		1200 (32.2)	2300 (61.6)	3000 (80.4)	3500 (93.8)
	15	1.00	1050 (28.1)	1580 (42.30)	3000 (80.4)	3500 (93.8)	3500 (93.8)
	25	1.70	1400 (37.5)	2400 (64.3)	3500 (93.8)	3500 (93.8)	
	30	2.10	1550 (41.5)	2700 (72.4)	3500 (93.8)		
	60	4.10	2300 (61.6)	3500 (93.8)			
	80	5.17	3000 (80.4)				
	100	6.90	3200 (85.8)				
	125	8.60	3500 (93.8)				
7 inches WC (17 mBAR) 655-788-001 1 inch WC (2 mBAR) droop 2 inches WC (5 mBAR) boost	2	0.14					1400 (37.5)
	5	0.34			1100 (29.5)	1700 (45.6)	2000 (53.6)
	10	0.69		750 (20.1)	2100 (56.3)	2400 (64.3)	3500 (93.8)
	15	1.00	1000 (26.8)	1050 (28.1)	3000 (80.4)	3500 (93.8)	3500 (93.8)
	25	1.70	1250 (33.5)	1950 (52.3)	3000 (80.4)	3500 (93.8)	
	30	2.10	1500 (40.2)	2550 (68.3)	3500 (93.8)		
	60	4.10	2500 (67.0)	3500 (93.8)			
	80	5.17	2700 (72.4)				
	100	6.90	3500 (93.8)				
	125	8.60	3500 (93.8)				
11 inches WC (27 mBAR) 655-788-002 ± 2 inches WC (5 mBAR)	2	0.14			500 (13.4)	700 (18.8)	1200 (32.2)
	5	0.34			1100 (29.5)	1500 (40.2)	2100 (56.3)
	10	0.69			1750 (46.9)	2500 (67.0)	3500 (93.8)
	15	1.00		1200 (32.2)	2500 (67.0)	3400 (91.1)	3500 (93.8)
	25	1.70		1900 (50.9)	3500 (93.8)	3500 (93.8)	
	30	2.10	1500 (40.2)	2100 (56.3)	3500 (93.8)		
	40	2.80	1900 (50.9)	3200 (85.8)			
	60	4.10	2300 (61.6)	2620 (70.2)			
	80	5.17	2750 (73.7)				
	100	6.90	3400 (91.1)				
125	8.60	3500 (93.8)					
20 inches WC (50 mBAR) 655-788-003 ± 3 inches WC (7 mBAR)	5	0.34				1000 (26.8)	1600 (42.9)
	10	0.69			1150 (30.8)	1850 (49.6)	2600 (69.7)
	15	1.00			1650 (44.2)	2700 (72.4)	3400 (91.1)
	25	1.70		1150 (30.8)	2700 (72.4)	3500 (93.8)	
	30	2.10	1200 (32.2)	1400 (37.5)	3200 (85.8)		
	40	2.80	1350 (36.2)	2000 (53.6)			
	60	4.10	1900 (50.9)	2900 (77.7)			
	80	5.17	2600 (69.7)				
	100	6.90	3000 (80.4)				
	125	8.60	3500 (93.8)				

1. Limited due to boost

- Shaded areas show where indicated droop would be exceeded regardless of capacity.
- Shaded areas show where maximum operating inlet pressure for a given port diameter is exceeded.

P301 & 302 Flow Capacities in SCFH (Nm³/h) of 0.6 Specific Gravity Natural Gas

Outlet Pressure, Spring Part Number, and Accuracy	Inlet Pressure		NPT 1-1/2 (DN40) & 2" (DN50) Body Size				
			Orifice Size, Inches (mm)				
	PSIG	BAR	3/16 (4.8)	1/4 (6.4)	3/8 (9.5)	1/2 (13)	3/4 (19)
5 inches WC (12 mBAR) 655-788-000 1 inch WC (2.5 mBAR) droop	2	0.14			750 (20.1)	1150 (30.8)	1700 (45.6)
	5	0.34		700 (18.8)	1550 (41.5)	2250 (60.3)	3500 (93.8)
	10	0.69		1400 (37.5)	2600 (69.7)	3500 (93.8)	3500 (93.8)
	15	1.00	1080 (28.9)	1850 (49.6)	3500 (93.8)	3500 (93.8)	3500 (93.8)
	25	1.70	1450 (38.9)	2450 (65.7)	2300 (61.6)	2600 (69.7)	
	30	2.10	1600 (42.9)	2750 (73.7)	1900 (50.9)		
	60	4.10	2600 (69.7)	3500 (93.8)			
	80	5.17	3300 (88.4)				
	100	6.90	3500 (93.8)				
	125	8.60	3500 (93.8)				
7 inches WC (17 mBAR) 655-788-001 1 inch WC (2 mBAR) droop 2 inches WC (5 mBAR) boost	2	0.14					1400 (37.5)
	5	0.34			1200 (26.8)	2000 (53.6)	3200 (85.8)
	10	0.69		1000 (26.8)	2400 (64.3)	3500 (93.8)	3500 (93.8)
	15	1.00	1050 (28.1)	1400 (37.5)	3300 (88.4)	3500 (93.8)	3500 (93.8)
	25	1.70	1400 (37.5)	2400 (64.3)	3500 (93.8)	2600 (69.7)	
	30	2.10	1600 (42.9)	1700 (72.4)	2400 (64.3)		
	60	4.10	2600 (69.7)	3500 (93.8)			
	80	5.17	3300 (88.4)				
	100	6.90	3500 (93.8)				
	125	8.60	3500 (93.8)				
11 inches WC (27 mBAR) 655-788-002 ± 2 inches WC (5 mBAR)	2	0.14			500 (13.4)	800 (21.4)	1250 (33.5)
	5	0.34			1150 (30.8)	1700 (45.6)	2500 (67.0)
	10	0.69			2000 (53.6)	3100 (83.1)	3500 (93.8)
	15	1.00		1250 (33.5)	3000 (80.4)	3500 (93.8)	3500 (93.8)
	25	1.70		195 (52.3)	3500 (93.8)	3500 (93.8)	
	30	2.10	1500 (40.2)	2300 (61.6)	3500 (93.8)		
	40	2.80	1900 (50.9)	3200 (85.8)			
	60	4.10	2650 (71.0)	3500 (93.8)			
	80	5.17	3250 (87.1)				
	100	6.90	3500 (93.8)				
125	8.60	3500 (93.8)					
20 inches WC (50 mBAR) 655-788-003 ± 3 inches WC (7 mBAR)	5	0.34				1050 (28.1)	1800 (48.2)
	10	0.69			1300 (34.8)	1900 (50.9)	3100 (83.1)
	15	1.00			1900 (50.9)	2850 (76.4)	3500 (93.8)
	25	1.70		1250 (33.5)	3100 (83.1)	3500 (93.8)	
	30	2.10	1300 (34.8)	1600 (42.9)	3500 (93.8)		
	40	2.80	1650 (44.2)	2200 (59.0)			
	60	4.10	2300 (61.6)	3300 (88.4)			
	80	5.17	2800 (75.0)				
	100	6.90	3200 (85.8)				
	125	8.60	3500 (93.8)				

1. Limited due to boost

- Shaded areas show where indicated droop would be exceeded regardless of capacity.
- Shaded areas show where maximum operating inlet pressure for a given port diameter is exceeded.

P301 & 302 Flow Capacities in SCFH (Nm³/h) of 0.6 Specific Gravity Natural Gas

Outlet Pressure, Spring Part Number, and Accuracy	Inlet Pressure		NPT 1-1/4 (DN32), 1-1/2 (DN40) & 2" (DN50) Body Sizes				
			Orifice Size, Inches (mm)				
	PSIG	BAR	3/16 (4.8)	1/4 (6.4)	3/8 (9.5)	1/2 (13)	3/4 (19)
1 PSIG Set (69 mBAR) 655-788-004 10% Droop	2	0.14	193 (5.2)	160 (4.3)	295 (7.9)	400 (10.7)	595 (15.9)
	5	0.34	300 (8.0)	381 (10.2)	440 (11.8)	748 (20.0)	1240 (33.2)
	10	0.69	450 (12.1)	465 (12.5)	690 (18.5)	1420 (38.1)	2200 (59.0)
	15	1.00	555 (14.9)	740 (19.8)	1290 (34.6)	2070 (55.5)	3350 (89.8)
	20	1.40	710 (19.0)	920 (24.7)	1880 (50.4)	2750 (73.7)	4500 (121.0)
	30	2.10	970 (26.0)	1160 (31.1)	3040 (81.5)	4180 (112.0)	5000 (134.0)
	40	2.80	1310 (35.1)	1620 (43.4)	4170 (112.0)	5000 (134.0)	5000 (134.0)
	60	4.10	1750 (46.9)	3300 (88.4)	5000 (134.0)	5000 (134.0)	
	80	5.17	2210 (59.2)	3400 (91.1)	5000 (134.0)		
	100	6.90	3100 (83.1)	3980 (107.0)			
	125	8.60	3760 (101.0)	3290 (88.2)			
3 PSIG Set (207 mBAR) 655-788-005 10% Droop	4	0.28	303 (8.2)	207 (5.6)	478 (12.8)	548 (14.7)	1060 (28.4)
	5	0.34	374(10.0)	452 (12.1)	606 (16.2)	905 (24.3)	1290 (34.6)
	10	0.69	515 (13.8)	670 (18.0)	1130 (30.3)	1740 (46.6)	2450 (65.7)
	15	1.00	735 (19.7)	905 (24.3)	1680 (45.0)	2250 (60.3)	3230 (86.6)
	20	1.40	970 (26.0)	1030 (37.6)	2000 (53.6)	2770 (74.2)	4130 (111.0)
	30	2.10	1420 (38.1)	1755 (47.0)	2970 (79.6)	3870 (104.0)	5000 (134.0)
	40	2.80	1700 (45.6)	2200 (59.0)	4030 (108.0)	5000 (134.0)	5000 (134.0)
	60	4.10	2390 (64.1)	3070 (82.3)	5000 (134.0)	5000 (134.0)	
	80	5.17	3030 (81.2)	4000 (107.0)	5000 (134.0)		
	100	6.90	3550 (95.1)	4380 (117.0)			
	125	8.60	4180 (112.0)	4970 (133.0)			
5 PSI Set (345 mBAR) 655-788-006 10% Droop	7	0.48					1480 (39.7)
	10	0.69	570 (15.3)	723 (19.4)	1030 (27.6)	1480 (39.7)	2040 (54.7)
	15	1.00	775 (20.8)	1030 (27.6)	1500 (40.2)	2130 (57.1)	3100 (83.1)
	20	1.40	980 (26.3)	1330 (35.6)	1940 (52.0)	2640 (70.8)	4080 (109.0)
	30	2.10	1390 (37.3)	1575 (42.2)	2710 (72.6)	3740 (100.0)	5000 (134.0)
	40	2.80	1740 (46.6)	2200 (59.0)	3480 (93.3)	4970 (133.0)	5000 (134.0)
	60	4.10	2380 (63.8)	3230 (86.6)	5000 (134.0)	5000 (134.0)	
	80	5.17	2970 (79.6)	4000 (107.0)	5000 (134.0)		
	100	6.90	3420 (91.7)	4830 (129.0)			
	100	6.90	389 (107.0)	5000 (134.0)			
6 PSI Set (414 mBAR) 655-788-007 10% Droop	10	0.69	495 (13.3)	677 (18.1)	905 (24.3)	1360 (36.4)	1940 (52.0)
	15	1.00	735 (19.7)	981 (26.3)	1390 (37.3)	1940 (52.0)	2840 (76.1)
	20	1.40	970 (26.0)	1225 (32.8)	1740 (46.6)	2500 (67.0)	3550 (95.1)
	30	2.10	1355 (36.3)	1650 (44.2)	2520 (67.5)	3680 (98.6)	5000 (134.0)
	40	2.80	1650 (44.2)	2100 (56.3)	3820 (102.0)	4700/126.0)	5000 (134.0)
	60	4.10	2270 (60.8)	3100 (83.1)	5000 (134.0)	5000 (134.0)	
	80	5.17	3070 (82.3)	3870 (104.0)	5000 (134.0)		
	100	6.90	3420 (91.7)	4500 (121.0)			
	125	8.60	4000 (107.0)	5000 (134.0)			

1. Limited due to boost

- Shaded areas show where indicated droop would be exceeded regardless of capacity.
- Shaded areas show where maximum operating inlet pressure for a given port diameter is exceeded.

P301 & 302 Flow Capacities in SCFH (Nm³/h) of 0.6 Specific Gravity Natural Gas

Outlet Pressure, Spring Part Number, and Accuracy	Inlet Pressure		NPT 1-1/4 (DN32), 1-1/2 (DN40) & 2" (DN50) Body Sizes				
			Orifice Size, Inches (mm)				
	PSIG	BAR	3/16 (4.8)	1/4 (6.4)	3/8 (9.5)	1/2 (13)	3/4 (19)
1 PSIG Set (69 mBAR) 655-788-004 20% Droop	2	0.14	265 (7.1)	180 (4.8)	505 (13.5)	683 (18.3)	1060 (28.4)
	5	0.34	465 (12.5)	425 (11.4)	980 (26.3)	1390 (37.3)	2070 (55.5)
	10	0.69	730 (19.6)	905 (24.3)	1580 (42.3)	2270 (60.8)	3360 (90.0)
	15	1.00	1030 (27.6)	1360 (36.4)	2270 (60.8)	3160 (84.7)	4500 (121.0)
	20	1.40	1230 (86.6)	1660 (44.5)	3030 (81.2)	4000 (107.0)	5000 (134.0)
	30	2.10	1570 (42.1)	2320 (62.2)	4320 (116.0)	5000 (134.0)	5000 (134.0)
	40	2.80	1940 (52.0)	2940 (78.8)	5000 (134.0)	5000 (134.0)	5000 (134.0)
	60	4.10	2650 (71.0)	4180 (112.0)	5000 (134.0)	5000 (134.0)	
	80	5.17	3230 (86.6)	4440 (119.0)	5000 (134.0)		
	100	6.90	3910 (105.0)	5000 (134.0)			
	125	8.60	4440 (119.0)	5000 (134.0)			
3 PSIG Set (207 mBar) 655-788-005 20% Droop	4	0.28	394 (10.6)	490 (13.1)	955 (25.6)	1290 (34.6)	1940 (52.0)
	5	0.34	485 (13.0)	645 (17.3)	1160 (31.1)	1610 (43.1)	2400 (64.3)
	10	0.69	825 (22.1)	1320 (35.4)	2040 (54.7)	2940 (78.8)	4260 (114.0)
	15	1.00	1060 (28.4)	1740 (46.6)	2640 (76.1)	3800 (102.0)	5000 (134.0)
	20	1.40	1250 (33.5)	2070 (55.5)	3430 (91.9)	4640 (124.0)	5000 (134.0)
	30	2.10	1570 (42.1)	2710 (72.6)	4780 (128.0)	5000 (134.0)	5000 (134.0)
	40	2.80	1940 (52.0)	3290 (88.2)	5000 (134.0)	5000 (134.0)	5000 (134.0)
	60	4.10	2630 (70.5)	4490 (120.0)	5000 (134.0)	5000 (134.0)	5000 (134.0)
	80	5.17	3290 (88.2)	5000 (134.0)	5000 (134.0)		
	100	6.90	4000 (107.0)	5000 (134.0)			
	125	8.60	4830 (129.0)	5000 (134.0)			
5 PSI Set (345 mBar) 655-788-006 20% Droop	7	0.48					2710 (72.6)
	10	0.69	750 (20.1)	1120 (30.0)	1830 (49.0)	2580 (69.1)	3740 (100.0)
	15	1.00	1040 (27.9)	1610 (43.1)	2580 (69.1)	3680 (98.6)	5000 (134.0)
	20	1.40	1260 (33.8)	2000 (53.6)	3300 (88.4)	4640 (124.0)	5000 (134.0)
	30	2.10	1640 (44.0)	2630 (70.5)	4580 (123.0)	5000 (134.0)	5000 (134.0)
	40	2.80	1910 (51.2)	3290 (88.2)	5000 (134.0)	5000 (134.0)	5000 (134.0)
	60	4.10	2610 (69.9)	4450 (119.0)	5000 (134.0)	5000 (134.0)	
	80	5.17	3250 (87.1)	5000 (134.0)	5000 (134.0)		
	100	6.90	3900 (105.0)	5000 (134.0)			
	125	8.60	4670 (125.0)	5000 (134.0)			
6 PSI Set (414 mBar) 655-788-007 20% Droop	10	0.69	710 (19.0)	1030 (27.6)	1680 (45.1)	2400 (64.3)	3520 (94.3)
	15	1.00	1030 (27.6)	1550 (41.5)	2520 (67.5)	3460 (92.7)	5000 (134.0)
	20	1.40	1220 (32.7)	1940 (52.0)	3120 (83.6)	4330 (116.0)	5000 (134.0)
	30	2.10	1650 (44.2)	2580 (69.1)	4420 (118.0)	5000 (134.0)	5000 (134.0)
	40	2.80	1910 (51.2)	3230 (86.6)	5000 (134.0)	5000 (134.0)	5000 (134.0)
	60	4.10	2610 (69.9)	4380 (117.0)	5000 (134.0)	5000 (134.0)	
	80	5.17	3260 (87.9)	5000 (134.0)	5000 (134.0)		
	100	6.90	3940 (106.0)	5000 (134.0)			
	125	8.60	4670 (125.0)	5000 (134.0)			

1. Limited due to boost

- Shaded areas show where indicated droop would be exceeded regardless of capacity.
- Shaded areas show where maximum operating inlet pressure for a given port diameter is exceeded.

Interchangeability between the BelGAS P200 series and the P300 series

The unique feature about the BelGAS P300 regulator is that it utilizes the BelGAS P200 series 1.5" x 2" and the 2" x 2" body using a simple adaptor ring. The simplicity of down-sizing a system when a BelGAS P200 unit is installed is as easy as removing

the 2 body-to-head bolts and installing a BelGAS P300 head with the appropriate adaptor and bolts. Or, if a 1.5" x 2" or 2" x 2" BelGAS P300 is installed, the BelGAS P300 head can be removed and a BelGAS P200 head installed to up-size your system.

It is important to know, a P300 head can be mounted to a P200 2" body with the appropriate adaptor and bolts. A P200 head cannot be mounted to any existing P300 body unless confirmed to be a BelGAS 2" P200/P300 body.

Remove the BelGAS 2" P300 head

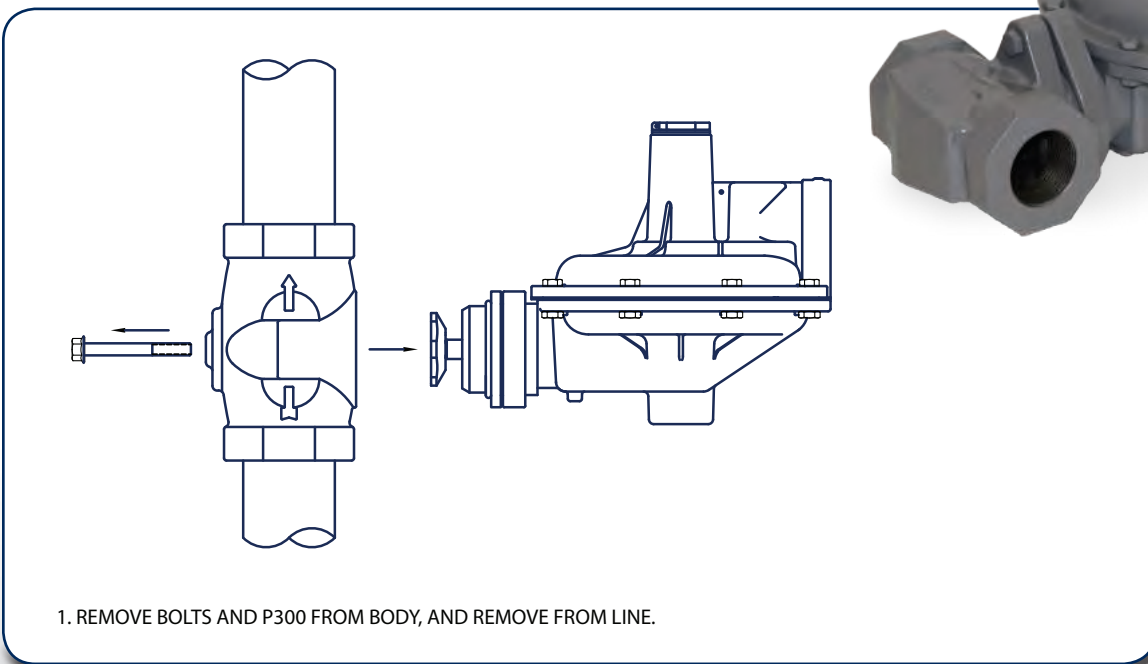

Install the BelGAS P200 head

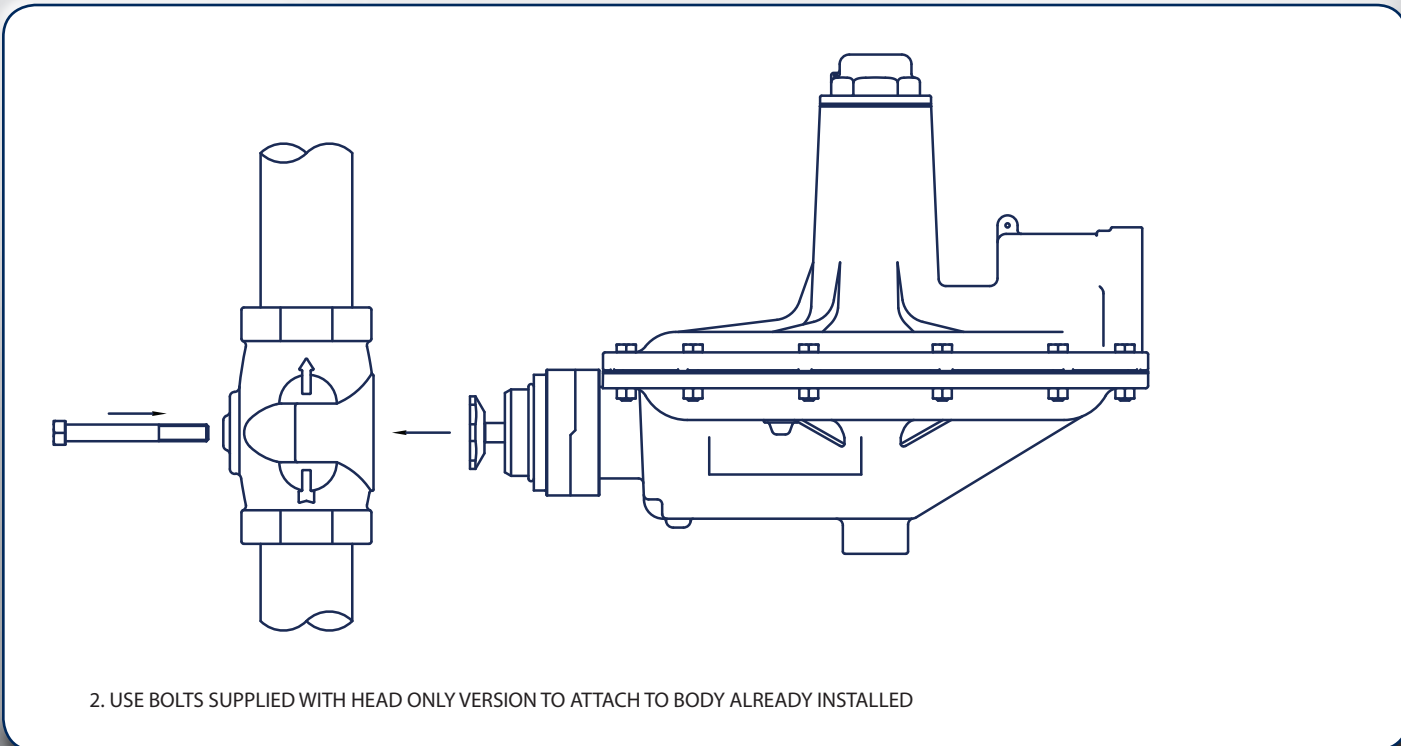

P300 Parts Drawing

P300

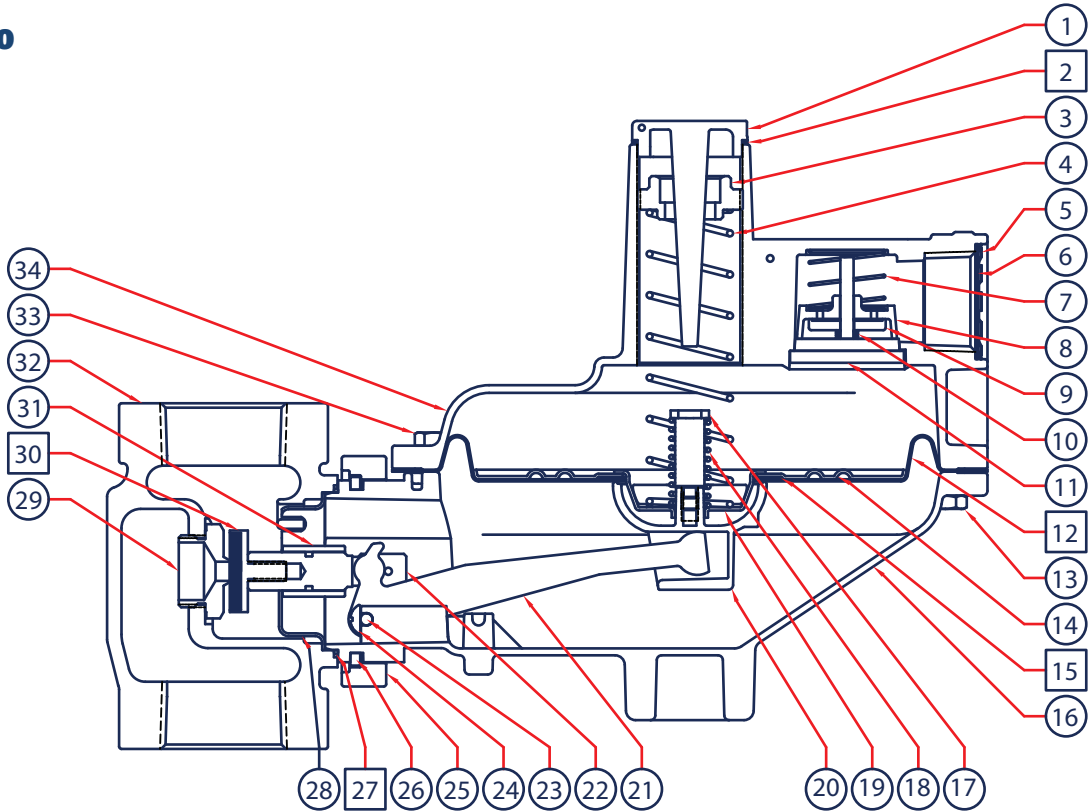

Parts included in Repair Kit 971-300-000

P300 H

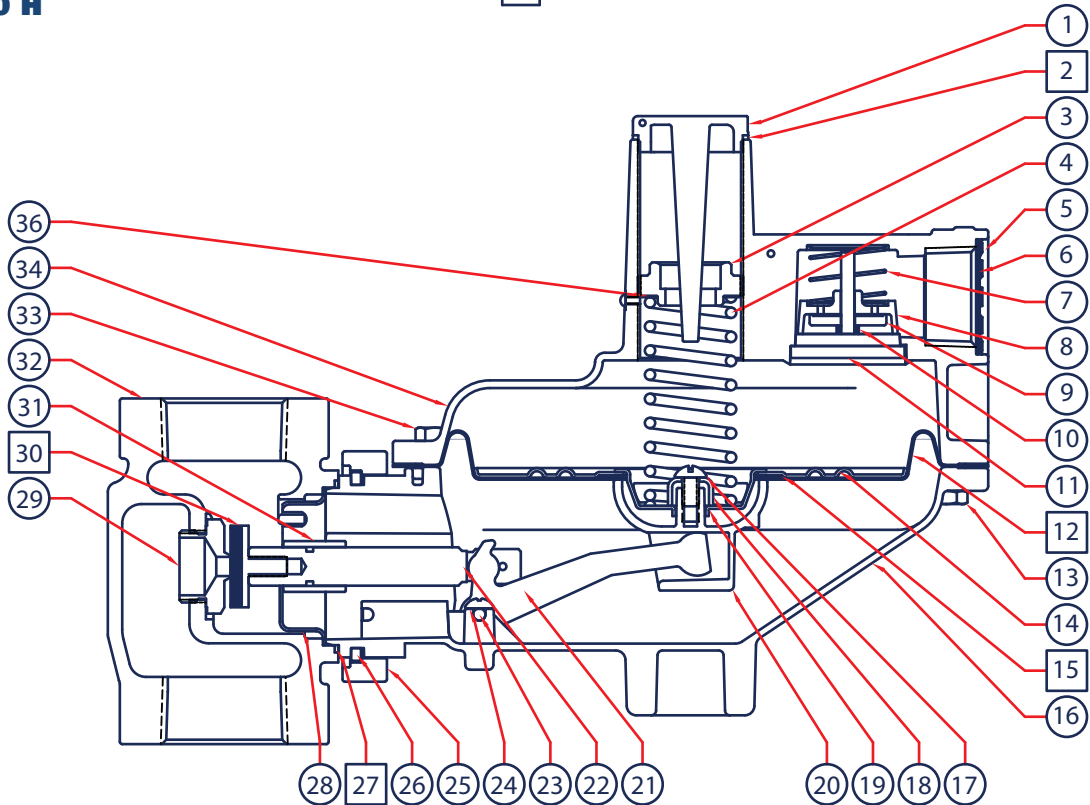

Parts included in Repair Kit 971-300-000

P300 Parts List

Item	Description	Qty.	Part Number
1	Bonnet Cap - Aluminum	1	610-096-000
2	Cap Gasket - Neoprene	1	624-106-000
3	Adjustment Screw - O Version	1	648-575-000
	Adjustment Screw - H Version		
4	Range Springs - Normal (O)	1	
	3.5" - 6.0" WC - Red, Plated Steel		655-788-000
	5.0" - 8.5" WC - Silver, Plated Steel		655-788-001
	6.0" - 14.0" WC - Blue, Plated Steel		655-788-002
	12.0" - 28.0" WC - Green, Plated Steel		655-788-003
	Range Springs - High (H)		
	1 - 2 PSI - Black, Plated Steel		655-788-004
	1.5 - 3.0 PSI - Olive drab, Plated Steel		655-788-005
	2.5 - 5.5 PSI - Yellow, Plated Steel		655-788-006
	4.5 - 8.0 PSI - Brown, Plated Steel		655-788-007
Vent Assembly Parts			
5	Retaining Ring	1	693-033-000
6	Vent Screen	1	647-027-000
7	Flapper Close Spring	1	655-788-010
8	Flapper Cap	1	661-017-000
8	Flapper Disk	1	661-016-000
10	Flapper Open Spring	1	655-788-009
11	Flapper Base	1	661-015-000
12	Diaphragms	1	618-111-000
	Diaphragm - Nitrile		
13	Build Screw Nuts- Plated Steel	8	634-000-019
14	Diaphragm Plate	1	638-091-000
15	Diaphragm Pad - Rubber	1	649-646-000

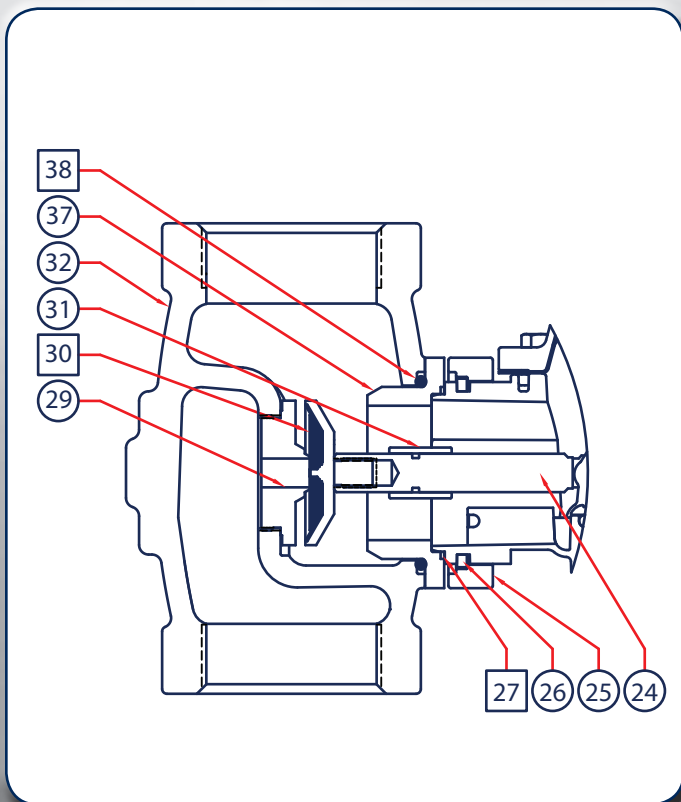

Item	Description	Qty.	Part Number
16	Lower Casing - Aluminum	1	629-259-000
17	Retainer Screw	1	648-577-000
	Relief Valve Stem		648-578-000
18	Relief Valve Spring	1	655-788-010
	Retainer	1	643-226-000
19	Spring Seat	1	650-199-000
20	Pusher Post - All 301 & 301H Series	1	637-340-000
	Pusher Post - All 302 & 302H Series		637-340-001
21	Lever - Plated Steel - 3010 & 3020	1	703-012-000
	Lever - Plated Steel - 301H & 302H		703-012-001
22	Valve Stem - 3010 & 3020	1	651-107-000
	Valve Stem - 301H & 302H		651-107-001
23	Lever Pivot Pin - Stainless	1	635-084-000
24	Self Tapping Screw	2	648-576-000
25	Union Ring - Aluminum	1	644-064-000
26	Split Ring	2	644-065-000
27	O-ring	1	649-341-000
28	Throat Baffle	1	686-007-000
29	Orifices (1-1/4 + 1-1/2 NPT Bodies)		
	3/16" Aluminum	1	688-074-000
	1/4" Aluminum	1	688-074-001
	3/8" Aluminum	1	688-074-002
	1/2" Aluminum	1	688-074-003
	3/4" Aluminum	1	688-074-004
	Orifices (2 + 2 x 1.5 NPT Bodies)		
	1/4" Aluminum	1	688-016-000
	3/8" Aluminum	1	688-016-001
	1/2" Aluminum	1	688-016-002
3/4" Aluminum	1	688-016-003	
30	Seat Assembly (1-1/4 + 1-1/2 NPT Bodies)	1	650-200-000
	Seat Assembly (2 + 2 x 1-1/2 NPT Bodies)	1	822-033-000
31	Stem Guide	1	626-122-000
32	Bodies		
	1-1/4" NPT - Iron		664-576-000
	1-1/2" NPT - Iron		664-576-001
	2" NPT - Iron		664-309-000
	2" NPT - Steel	1	664-342-000
	2" x 1-1/2" - Iron		664-349-000
	2" x 1-1/2" - Steel		664-349-001
	125# FF Iron		664-377-000
150# RF Steel		665-378-000	
33	Build Screws - Plated Steel	8	648-567-003
34	Bonnet - Aluminum - All O Versions	1	604-274-000
	Bonnet - Aluminum - H Version / 1-2 & 1.5-3 Spring		800-135-000
	Bonnet - Aluminum - H Version / 2.5-5 & 4.5-8 Spring		800-135-001
35	Hex Cap Screw	1	648-066-000
36	Slip Disk	1	644-066-000
37	Body Adaptor for 2" NPT & Flanged Body Only	1	654-199-000
38	Body Adaptor O-ring for 2" NPT & Flanged Body Only	1	649-000-152